

Pump Type	Nominal Delivery lpm @ 1500 rpm	Pressure P1 bar	Max Speed rpm	Dimension			
				A	B	Suction	Delivery
				mm	mm	C	D
P-10	1.5	200	2900	40.00	86.00	G 3/8"	G 3/8"
P-16	2.4	200	2900	41.30	88.60		
P-20	3.0	200	2900	42.10	90.20		
P-25	3.8	200	2900	43.20	92.60		
P-37	5.6	200	2900	45.50	96.90		
P-42	6.3	200	2900	46.60	99.10		
P-50	7.5	200	2900	48.00	102.10	G 1/2"	

Rotation-"A" (Anticlockwise)

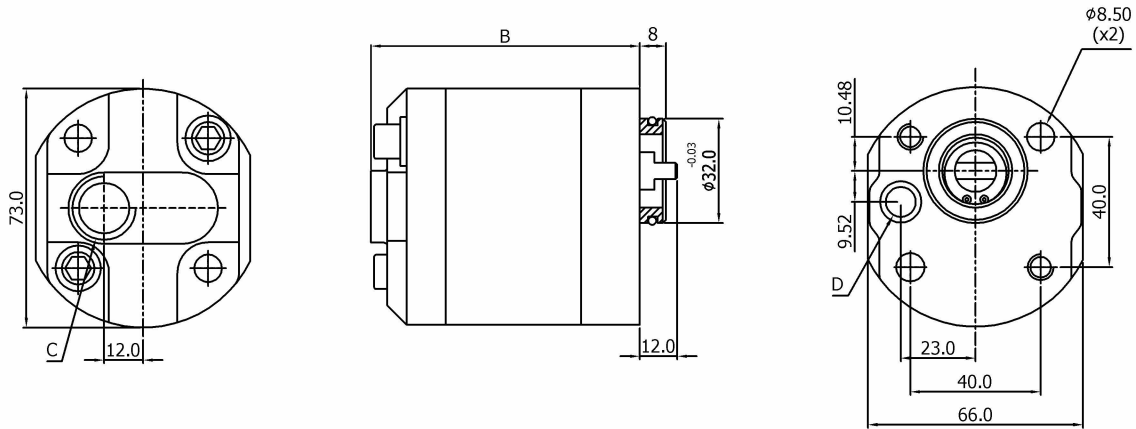

Rotation-"C" (Clockwise)

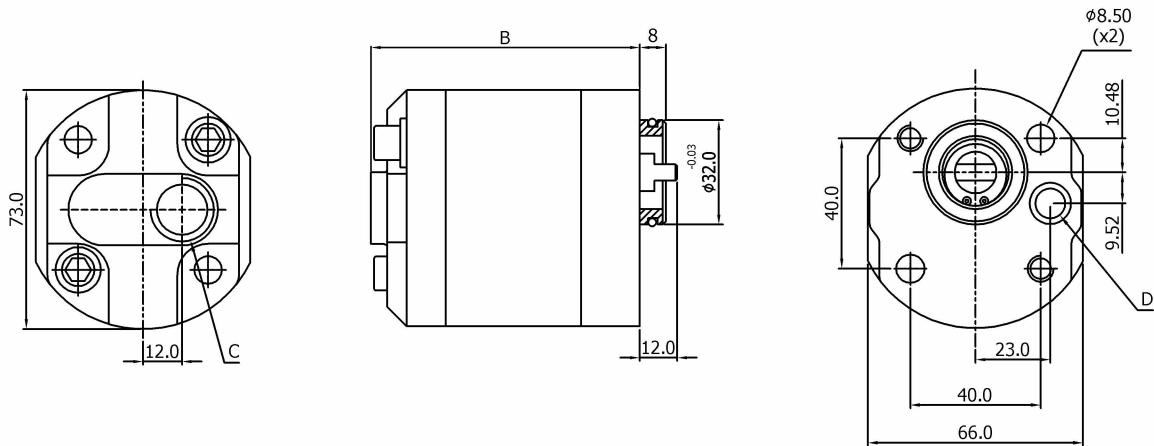

Pump Type	Nominal Delivery lpm @ 1500 rpm	Pressure P1 bar	Max Speed rpm	Dimension		
				B	Suction	Delivery
				mm	C	D
P-10	1.5	200	2900	86.00	G 3/8"	$\phi 9.20$
P-16	2.4	200	2900	88.60		
P-20	3.0	200	2900	90.20		
P-25	3.8	200	2900	92.60		
P-37	5.6	200	2900	96.90		
P-42	6.3	200	2900	99.10		
P-50	7.5	200	2900	102.10		

SHAFTS

W

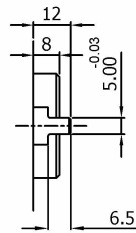

MOUNTING FLANGE

K

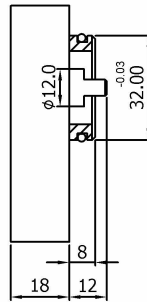
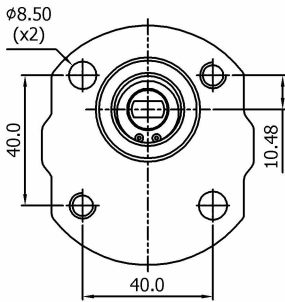

J

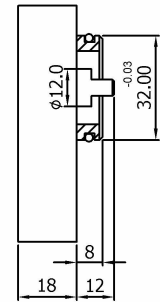
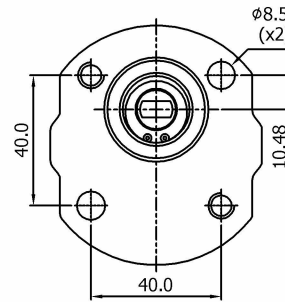

M

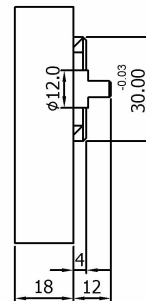
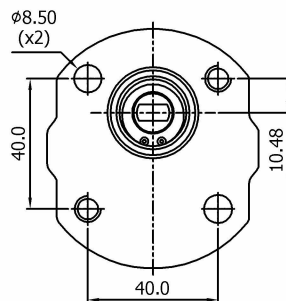

P

CW

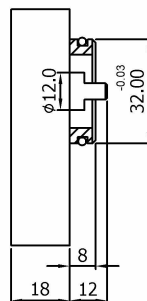
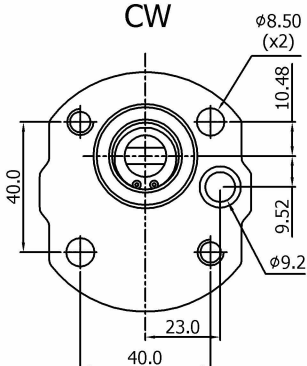

A/CW

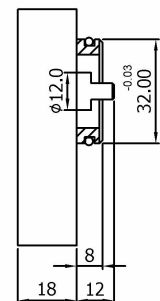
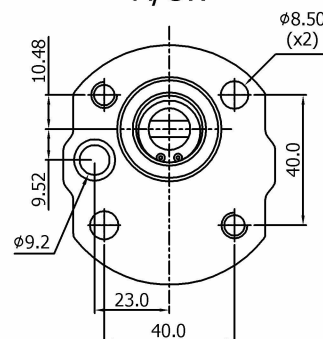

PORTS

CODE - G

Suction

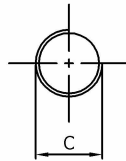

Delivery

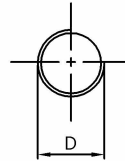

TYPE	C	D
P10 to P25	G 3/8"	G 3/8"
P37 to P50	G 1/2"	G 3/8"

REAR COVER

CODE - B

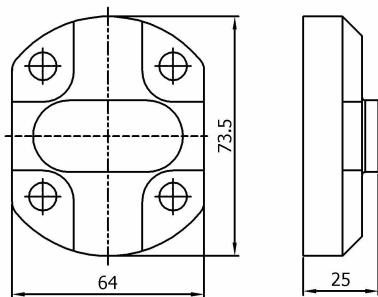

CODE - R

